

INTACTON

OPTICAL LENGTH AND VELOCITY SENSOR OPTIPACT-S1



Main Features

- Contact-free optical measurement principle
- Measurement in 2 orthogonal axes, alignment effort is significantly minimized by using the resulting direction function
- Compact industrial design
- Velocity range up to +/- 4 m/s
- Detection of standstill
- Detection of direction of motion
- Allows deviation from nominal working distance
- Suited for rough and structured surfaces
- Measurement uncertainty <1 %
- Self adapting to measurement object
- Long life LED illumination
- Programmable via RS232

Mechanical Structure

- Aluminium housing
- Front window made of unbreakable, scratch resistant and durable plastic
- Protection class IP 65

Programmable Parameters

- Resolution
- Positive / negative direction
- Frame rate

Electrical Features

- +5V or 10V..30V supply voltage selectable
- Polarity inversion protection
- Over-voltage-peak protection
- 2 status LEDs

INTACTON

OPTICAL LENGTH AND VELOCITY SENSOR OPTIPACT-S1

Technical data

Sensor Properties

Velocity measurement range	4 m/s to + 4 m/s
Measurement uncertainty	<1 % relative to value of measured length. Based on a total length of 10 m and constant velocity of 4 m/s.
Internal Resolution	65 µm
Output Resolution	100 µm, other resolutions programmable
Materials to measure	Rough and structured materials are best suited for measurement. The following listing is by far incomplete and provides only a selection: Textiles, webs, fleece, wood etc.

Optics and Illumination

	OPT-__-_____- 004 10 -
Distance to object (*)	42 mm
Distance deviation	±10 %
Measurement spot size	< 4 mm ² (2 mm x 2 mm)
Illumination	LED

(*) other measurement distances on request

Mechanical data

Housing material	Aluminium
Shock resistance (EN 60068-2-27)	≤ 25 g (half sine, 6 ms) (*)
Permanent shock (EN 60028-2-29)	≤ 10 g (half sine, 16 ms) (*)
Vibration (EN 60068-2-6)	≤ 1 g (5 Hz ... 200 Hz, sine) (*)
Weight (standard version)	approximately 250 g
Mounting	2 slotted holes for M4

(*) corresponding to class 3M5 (EN 60721-3-3: compliant to applications associated with significant vibrations, e.g. caused by machines or vehicles, or shocks with high density of energy, e.g. caused by heavy machines or conveyor belts)

OPTICAL LENGTH AND VELOCITY SENSOR OPTIPACT

Mechanical drawings

Fig. 1 Mechanical drawing (all dimensions in mm)

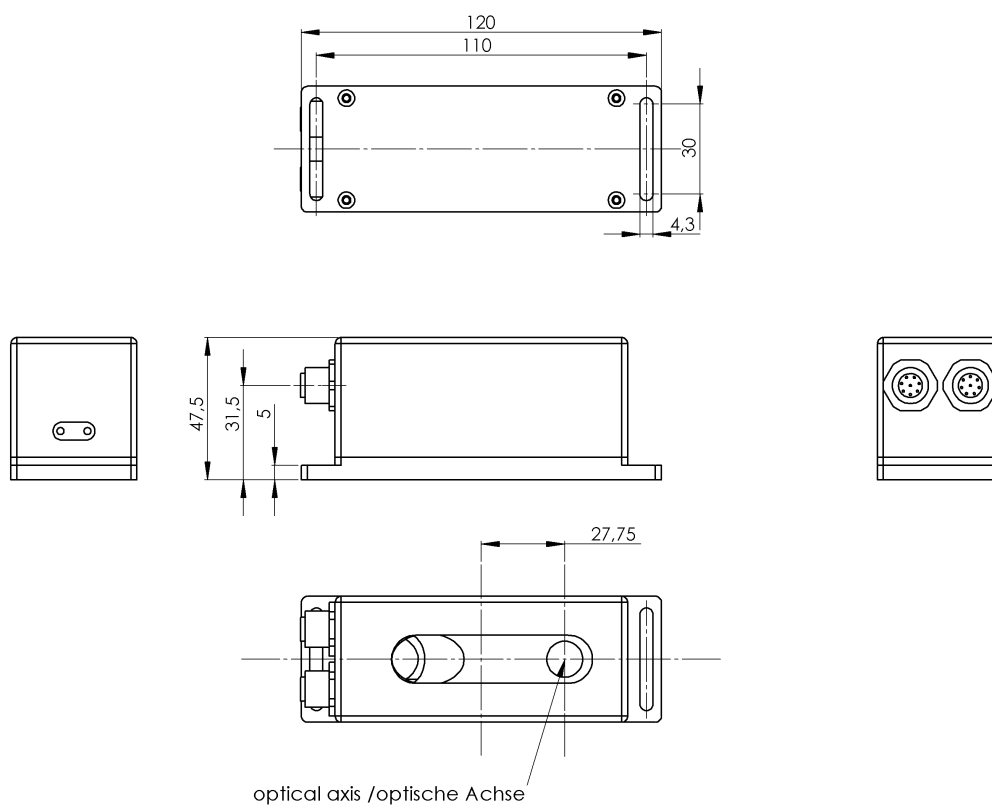

INTACTON

OPTICAL LENGTH AND VELOCITY SENSOR OPTIPACT-S1

Electrical data

Supply voltage	5 V or 10 - 30 V(*) DC (absolute limit)
Power consumption	≤ 2.5 Watt
EMC	Emitted interference: EN 61000-6-4
	Noise immunity: EN 61000-6-2
Interface	Field bus (**), Incremental, SSI
Data transfer rates	
- Incremental interface, (maximum step frequency)	1 D: up to 70 kHz 2 D: up to 35 kHz
- SSI	100 kHz - 300 kHz
Electrical lifetime	> 10 ⁵ h

(*) Supply voltage according to EN 50 178 (safety extra-low voltage).

(**) On request

Environmental conditions

Operating temperature	-15 to + 55 °C
Storage temperature	- 20 to + 60 °C
Humidity	80 % (without liquid state)
Protection class (EN 60529)	Enclosure: IP 65

INTACTON

OPTICAL LENGTH AND VELOCITY SENSOR OPTIPACT

Interface

Synchronous Serial Interface (SSI)

The SSI interface can be used to transmit an ascending length or a velocity.

Electrical data

Noise immunity	Balanced line transmission provides high noise immunity
Paired lines	Shielded and twisted pair lines are essential to maximize noise immunity.
Clock input	Galvanically isolated via opto-coupler
Clock frequency	100 kHz – 300 kHz
Differential input voltage for clock	Minimum 2,8 V / maximum 5 V
Output driver circuit	Line Driver, RS422 compatible
Maximum output current	25 mA

Timing

Delay time t_p	< 30 μ s
Latency time t_m (at single shift)	> 1,5 ms
Latency time t_m (at multiple shift)	> 55 μ s

Data transmission

Output data is transmitted synchronously to the clock signal of the control system (e.g. PLC or a counter card). When non-operational clock and data line levels are high. As soon as the clock signal of a sequence changes for the first time from high (H) to low (L), data is latched for transmission.

Data bits are shifted on rising clock edges starting with the most significant bit. Transmission ends on the last rising clock edge and is terminated after excession of the ssi delay time (latch is cleared after 30 μ s).

To avoid multiple transmission of identical data, requests should not follow each other faster than 1.5 ms (cycle time of internal measurement).

The maximum data word length is 31 bits (15 bits for x-axis related data starting with the first rising edge and 15 bits for y-axis related data, followed by a zero bit). Thus, a full data transmission requires 31 clock cycles. For 1 dimensional operation, a clock burst of 16 cycles is sufficient (including the zero bit). All data words must be interpreted as absolute values, therefore length progress between two readings is given by the difference value. Velocity information containing negative values are encoded in twos complement format.

INTACTON

OPTICAL LENGTH AND VELOCITY SENSOR OPTIPACT-S1

Signal diagram 1D

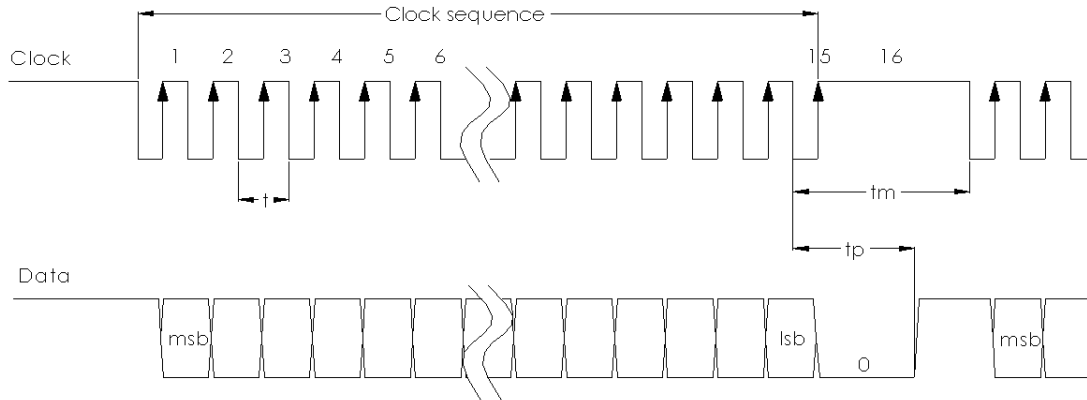

$t_p < 30 \mu s$ $t_m > 55 \mu s$ (at multiple transfer) / $t_m > 1.5 ms$ (at single transfer)

$t < t_m$

Fig. 2 1D data transmission signal diagram

Signal diagram 2D

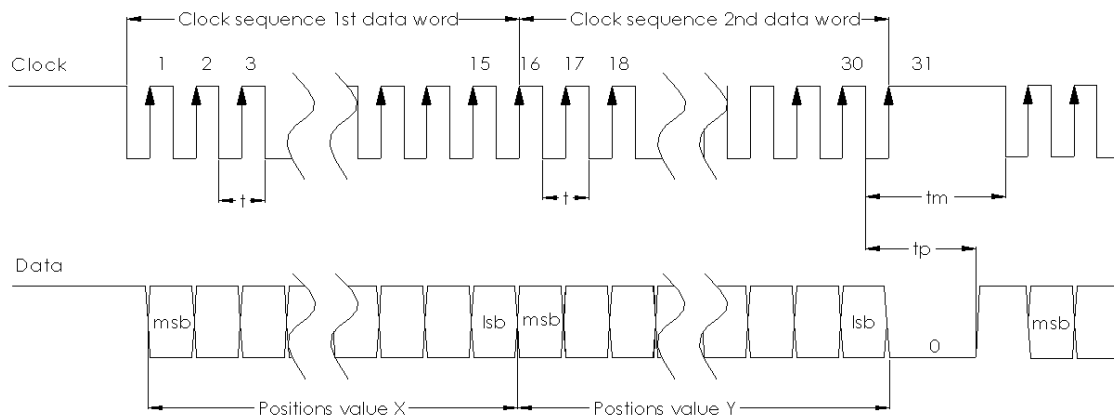

$t_p < 30 \mu s$ $t_m > 55 \mu s$ (at multiple transfer) / $t_m > 1.5 ms$ (at single transfer)

$t < t_m$

Fig. 3 2D data transmission signal diagram

Multiple transfer

For redundancy testing, data can be transmitted multiple times by requesting data faster than 0.75 ms (the delay time of 30 μs has still to be accounted for). Performing requests in this

manner result in reception of identical data words on each demand.

After expiration of the latency time (1.5 ms), the sensor provides data from an updated measurement.

INTACTON

OPTICAL LENGTH AND VELOCITY SENSOR OPTIPACT

Incremental interface

Incremental length information is provided by a quadrature signal pair consisting of two square pulses, shifted in phase to each other by 90°.

Electrical data

Maximum output frequency	1D: up to 70 kHz at 4x edge count up to 17.5 kHz at 1x edge count 2D: up to 35 kHz per measurement axis at 4x edge count up to 8.75 kHz per measurement axis at 1x edge count
Velocity measurement range	$v_{\max} = \pm 4 \text{ m/s}$ @ 250 μm per increment $v_{\max} = \pm 1,75 \text{ m/s}$ @ 100 μm per increment $v_{\max} = \pm 1,13 \text{ m/s}$ @ 65 μm per increment (minimum resolution)
Resolution (output)	Minimum 1 increment = 65 μm (smallest step size 16,25 μm)(* 1 increment = 100 μm (smallest step size 25 μm) 1 increment = 250 μm (smallest step size 62,5 μm)
Signals	
One-dimensional operation	channel A, /A, B, /B
X/Y-operation	X-axis: X_A, /X_A, X_B, /X_B ; Y-axis: Y_A, /Y_A, Y_B, /Y_B
Phase shift	90° between channel A and B in each case
Line driver version	
Maximum output current data	25 mA
Push-Pull version	
Maximum output current	25 mA
Maximum output voltage	Operating voltage
Short-circuit proof	Signal output against each other and to ground

(*) for reference see signal diagram

INTACTON

OPTICAL LENGTH AND VELOCITY SENSOR OPTIPACT-S1

Signal diagram

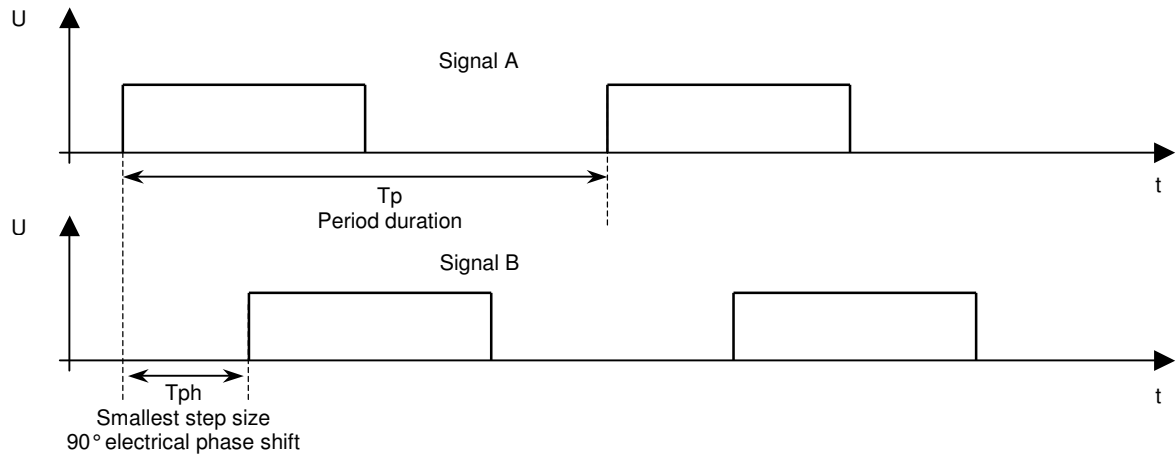

Signal A: Square signal A, incremental signal
Signal B: Square signal B, incremental signal

Tp: Period duration
Tph: 90° electrical phase shift

OPTICAL LENGTH AND VELOCITY SENSOR OPTIPACT

Electrical Connection

Plug

8 pin male M12 connector

Pin Number	SSI Signal	Incremental Signal	
		1 axis	2 axes
1	Data +	A	X_A
2	Data -	/A	/X_A
3	Clock +	B	X_B
4	Clock -	/B	/X_B
5	+ U _{b_Ext}	+ U _{b_Ext}	+ U _{b_Ext}
6	Gnd_Ext	Gnd_Ext	Gnd_Ext
7	RS232 Rx	RS232 Rx	RS232 Rx
8	RS232 Tx	RS232 Tx	RS232 Tx

Stecker
Male Connector

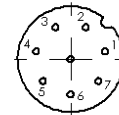

Dose
Female Connector

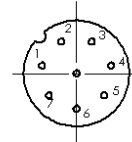

8 pin female M12 connector

Pin Number	SSI Signal	Incremental Signal	
		1 axis	2 axes
1	n.a.	n.a.	Y_A
2	n.a.	n.a.	/Y_A
3	n.a.	n.a.	Y_B
4	n.a.	n.a.	/Y_B
5	Start/Stop	Start/Stop	Start/Stop
6	Gnd_Ext	Gnd_Ext	Gnd_Ext
7	Motion	Motion	Motion
8	Ready	Ready	Ready

INTACTON

OPTICAL LENGTH AND VELOCITY SENSOR OPTIPACT-S1

Diagnostic LED's

The LEDs mounted on the housing backside allow easy diagnostics during initial setup of the

sensor or in case of fault without any additional tools.

Programmable Parameters (via RS232)

Frame rate	Defines the frame rate of the sensor. As an alternative the frame rate is adjusted automatically.
Resolution (output)	The resolution of the output value is given by the physical resolution (65 μm) multiplied with a user defined scale factor.
Sign of direction	Defines the sign of motion.

OPTICAL LENGTH AND VELOCITY SENSOR OPTIPACT

Mounting Situation

The drawing shows the measurement setup. Please note the reference points for the working distance and the orientation of the sensor relative to the direction of movement. The slotted holes in the base plate allow flexible adjustment of the sensor.

The coordinates of the optical axes are given in the mechanical drawing. During operation of the sensor the area between the object and the window must not be obstructed.

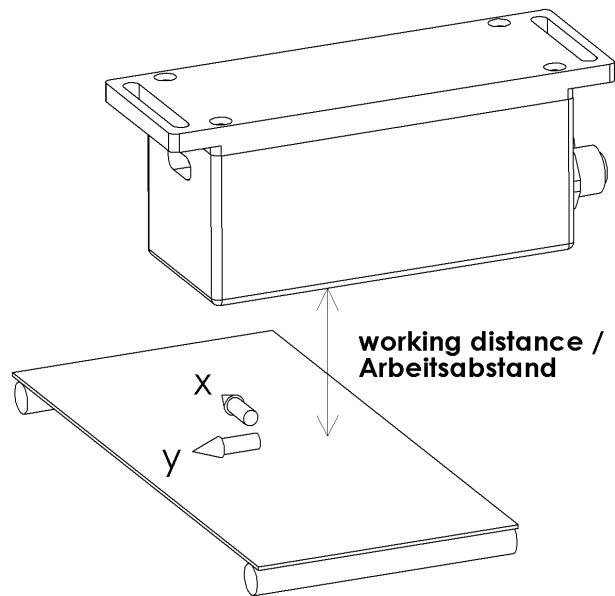

INTACTON

OPTICAL LENGTH AND VELOCITY SENSOR OPTIPACT-S1

Models / Ordering Description

Description	Type Key	
Optipact	OPT-	S 1
Model	S	
Generation		1
Velocity Range	-4..+4 m/s	N 0 0 4 0 0 4
Working distance (*)	42 mm	0 0 1
Distance deviation	10% of working distance	1 0
Image sensor	Internal identifier	1
Measurement axis	1 measurement axis (resulting)	1
	2 orthogonal axes	2
Incremental- interface	without	0
	RS422 compatible	1
	Push-Pull (output level = +U _b)	2
	TTL	3
Field bus interface (**)	without	0
	SSI (RS422 compatible)	1
	SSI with Push-Pull (output level = +U _b)	2
	SSI with TTL	3
Connection type	Connector	P
Supply voltage	10 – 30 V	1
	5 V	2
Housing	Aluminium	A
Version		0
Options	without	00

(*) further working distances on request

(**) further field bus interfaces on request

Standard = bold, further models on request

INTACTON

OPTICAL LENGTH AND VELOCITY SENSOR OPTIPACT

Available models

	Modell	Generation	Velocity range	Working distance	Distance deviation	Image sensor	Measurement axes	Incremental-interface	Field bus interface	Connection type	Supply voltage	Housing	Version	Options
OPT-	S	1	N 004004	004	10 -	1	-	0	1	P	1 -	A	0	00
OPT-	S	1	N 004004	004	10 -	1	-	0	2	P	1 -	A	0	00
OPT-	S	1	N 004004	004	10 -	1	-	0	3	P	1 -	A	0	00
OPT-	S	1	N 004004	004	10 -	1	-	1	0	P	1 -	A	0	00
OPT-	S	1	N 004004	004	10 -	1	-	2	0	P	1 -	A	0	00
OPT-	S	1	N 004004	004	10 -	1	-	3	0	P	1 -	A	0	00

Accessories and Documentation

Description	Type
Male connector, counterpart	M12-male connector, IP 65 M12-S8
Female counterpart counterpart	M12-female connector, IP 65 M12-D8
Manual (*)	Installation- and configuration, German UMD-OPT
Manual (*)	Installation- and configuration, English UME-OPT

(*) Visit our homepage www.intacton.com. All data sheets and manuals can be downloaded free of charge from our homepage.

We do not assume responsibility for technical inaccuracies or omissions. Specifications are subject to change without notice.